

SEPARATORE con portatubi

DIVIDER with Tube Holder

MITSUBISHI L200 MY16 D/C

COD. PK 52251



Fig.	Codice	Descrizione	Q.tà
A		SEPARATORE	1
B	110812103	STAFFE SUPERIORI	2
C	110812105	STAFFA SINISTRA	1
D	110812106	STAFFA DESTRA	1
E	802008	INSERTI FILETTATI Ø8	16
F	100825	VITE TE 8x25	16
G	700924	RONDELLA 8 x 24	16
H	200855	VITE TCE 8x55	2
L	600801	DADO M.8	2
M	700817	RONDELLA 8x16	4

Fig.	Code	Description	Q.ty
A		DIVIDER	1
B	110812103	UPPER BRACKET	2
C	110812105	LEFT BRACKET	1
D	110812106	RIGHT BRACKET	1
E	802008	THREADED INSERT Ø8	16
F	100825	SCREW TE 8x25	16
G	700924	WASHER 8 x 24	16
H	200855	SCREW TCE 8x55	2
L	600801	NUT M.8	2
M	700817	WASHER 8x16	4

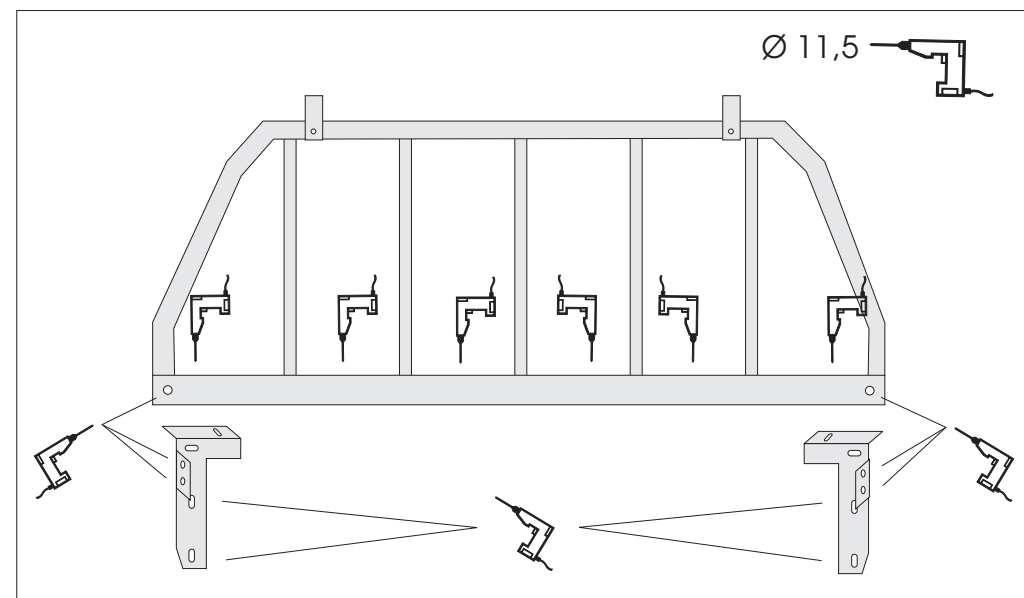

Forare il cassone della vettura in corrispondenza dei fori delle staffe e del separatore.
Fissare gli inserti filettati al cassone con l'apposito attrezzo e montare le staffe e il separatore alla vettura.

Drill the metal sheet of the car in coincidence of the brackets and divider holes.
Fix the threaded insert with specific tool and mount the brackets and the divider to the car.

